

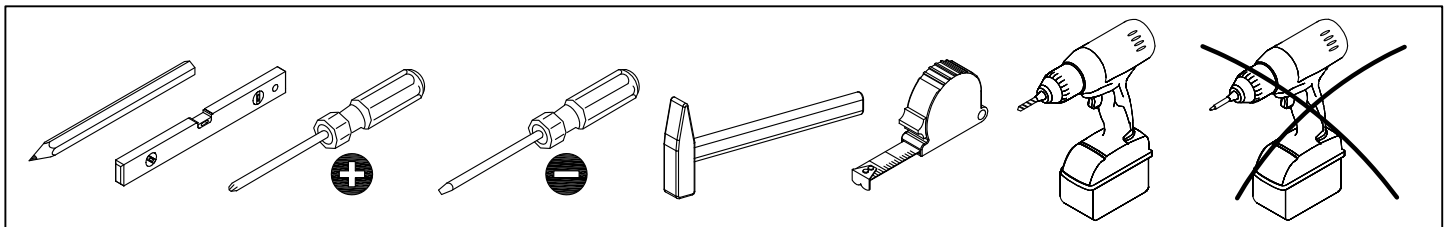

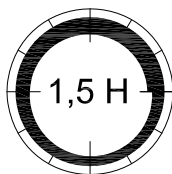

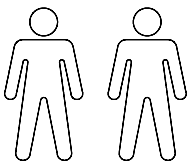

# ASTON

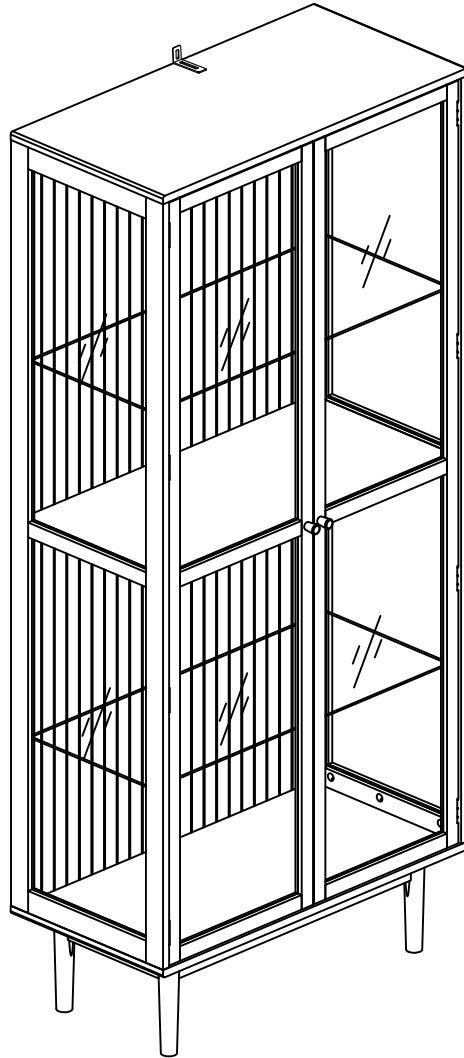
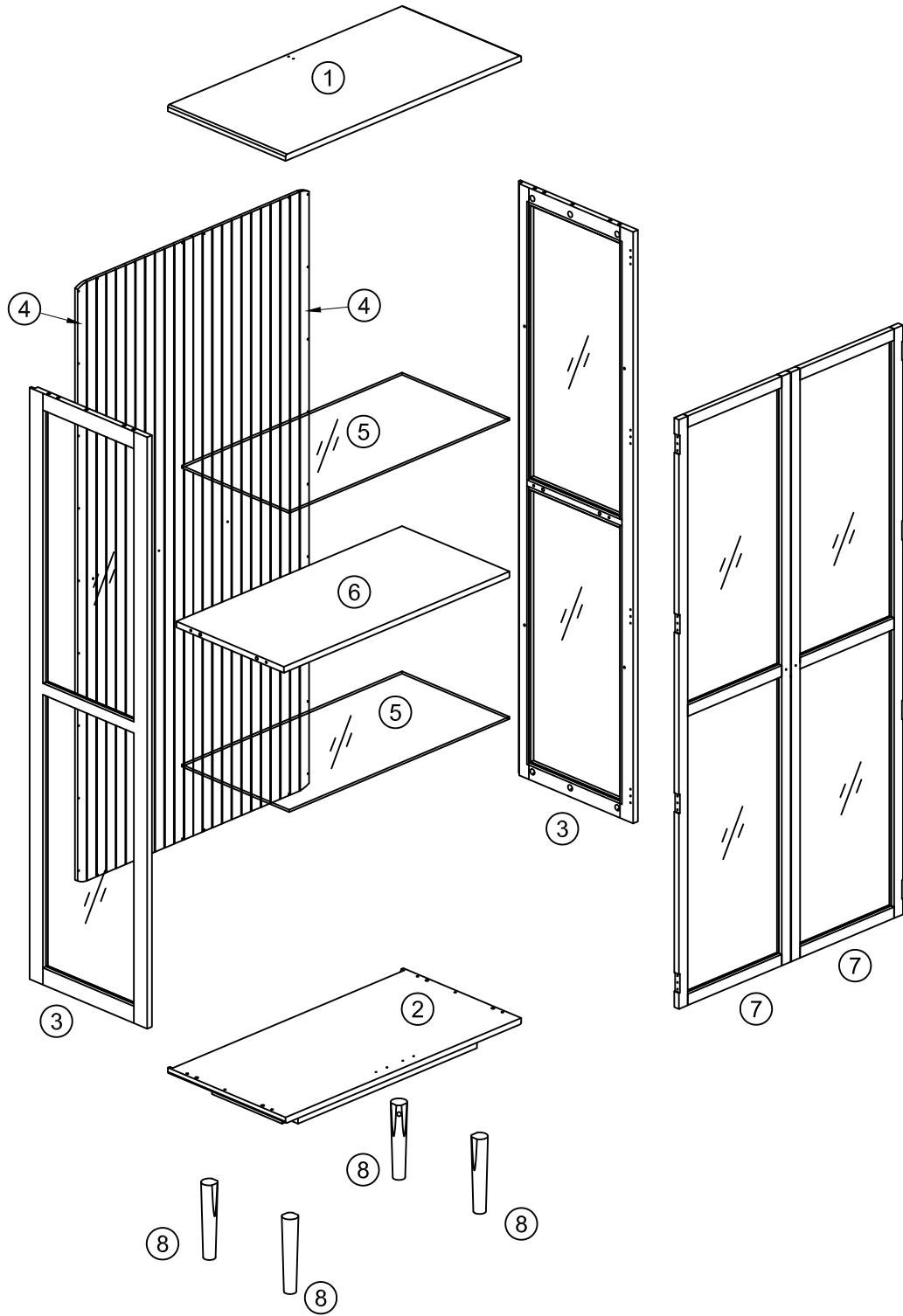

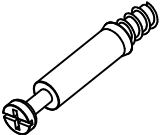

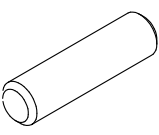
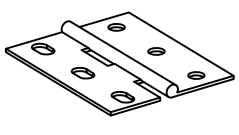
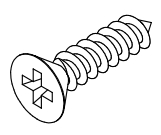
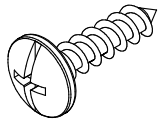
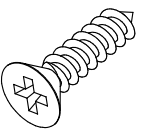
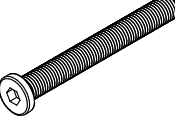
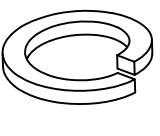
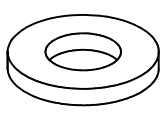
			✓
①	1	800 x 400 x 16	
②	1	800 x 400 x 66	
③	2	1568 x 399 x 16	
④	2	1588 x 393 x 9	

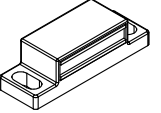
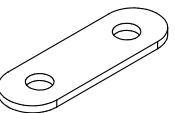
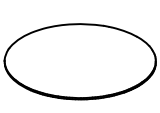
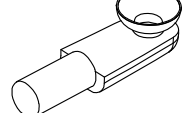
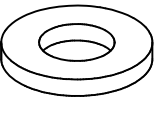
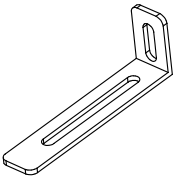
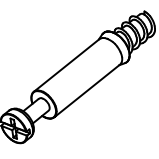
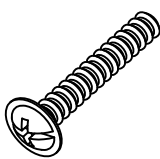
			✓
⑤	2	764 x 365 x 6	
⑥	1	766 x 365 x 16	
⑦	2	1562 x 379 x 16	
⑧	4	200 x Ø40 / Ø30	

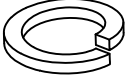

<p>A x 12</p>  <p>Ø6 x 34 mm</p>	<p>B x 16</p>  <p>Ø15 x 12 mm</p>	<p>C x 12</p>  <p>Ø8 x 30 mm</p>	<p>D x 8</p>  <p>50 x 37 mm</p>	<p>E x 48</p>  <p>Ø3.5 x 16 mm</p>
<p>F x 44</p>  <p>Ø3.5 x 16 mm</p>	<p>G x 8</p>  <p>Ø3 x 12 mm</p>	<p>H x 4</p>  <p>M8 x 65 mm</p>	<p>J x 4</p>  <p>Ø8 mm</p>	<p>K x 4</p>  <p>Ø8/Ø19 mm</p>
<p>L x 1</p>  <p>5 mm</p>	<p>M x 4</p>  <p>46 x 16 x 13 mm</p>	<p>N x 4</p>  <p>45 x 12 mm</p>	<p>P x 12</p>  <p>Ø20 mm</p>	<p>Q x 8</p>  <p>Ø5 mm</p>
<p>R x 2</p>  <p>Ø4/Ø12 mm</p>	<p>S x 1</p>  <p>75 x 15 x 25 mm</p>	<p>T x 4</p>  <p>Ø6 x 43 mm</p>	<p>U x 2</p>  <p>M4 x 21 mm</p>	<p>V x 2</p>  <p>Ø20/Ø15 x 25 mm</p>

# 1

H x 4  M8 x 65 mm	J x 4  Ø8 mm	K x 4  Ø8/Ø19 mm	L x 1  5 mm
--	---	---	--

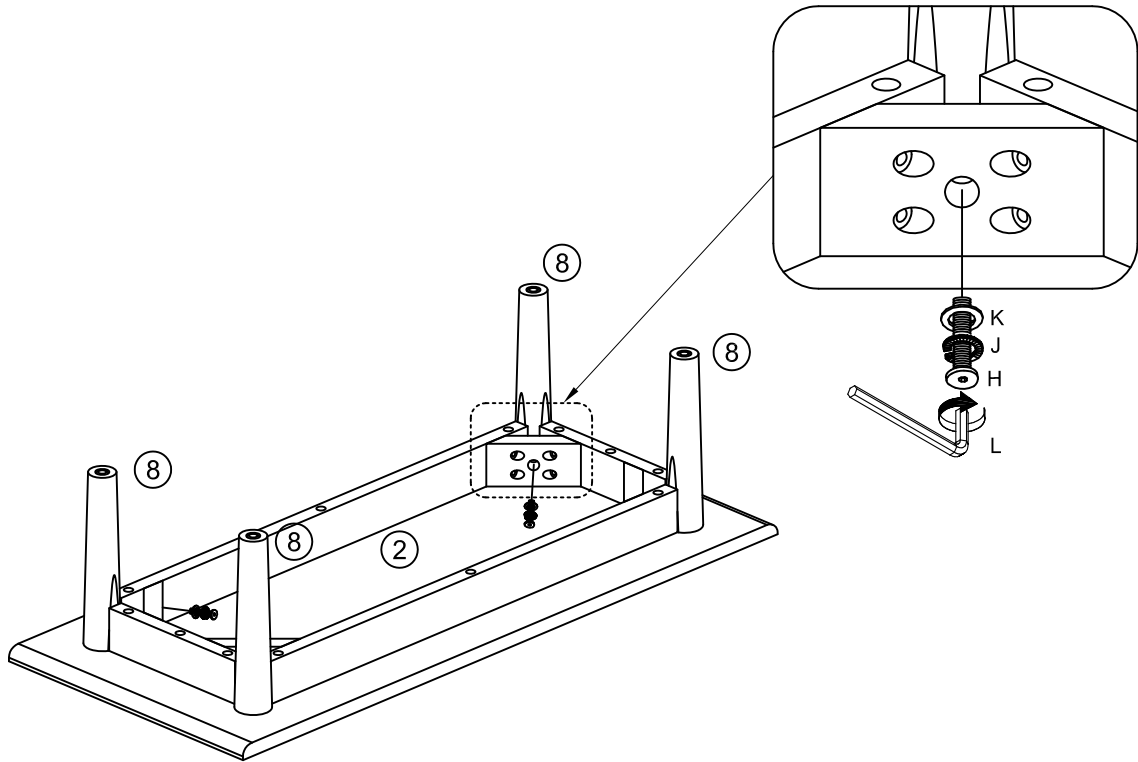

# 2

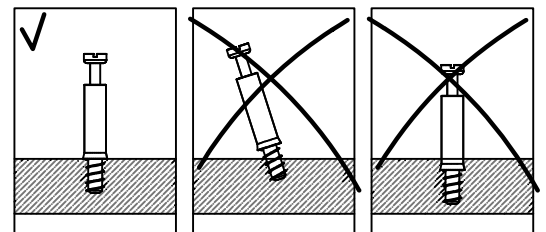
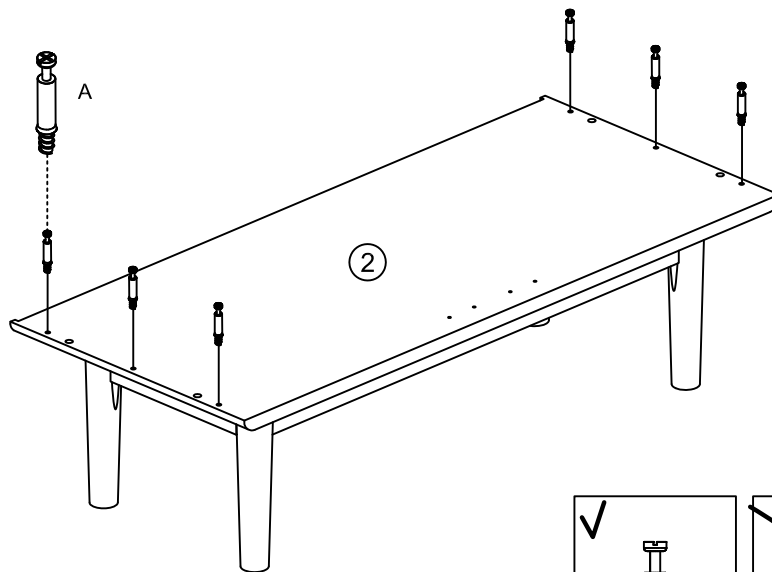
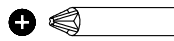
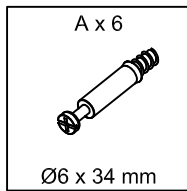

# 3

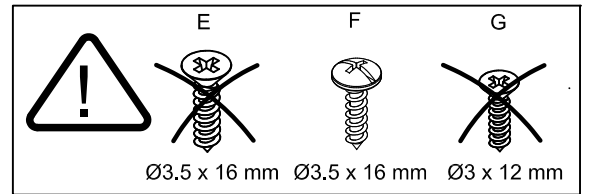
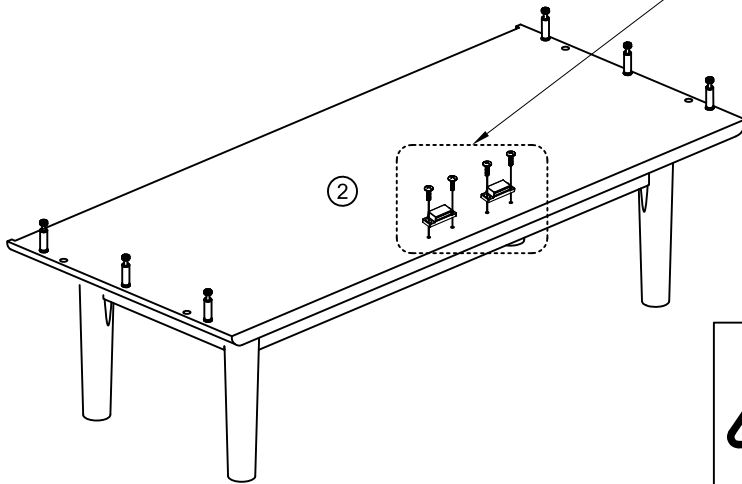
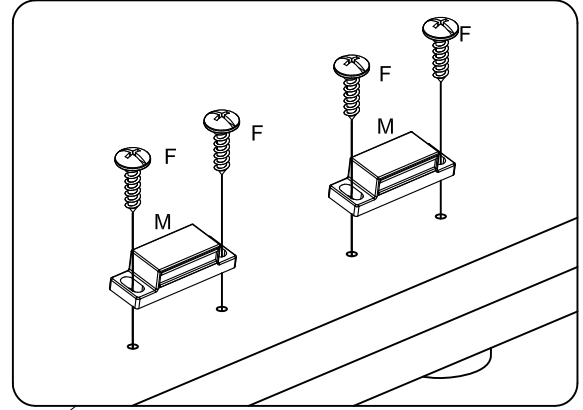
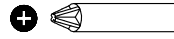
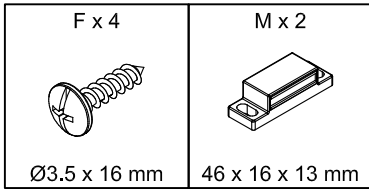

# 4

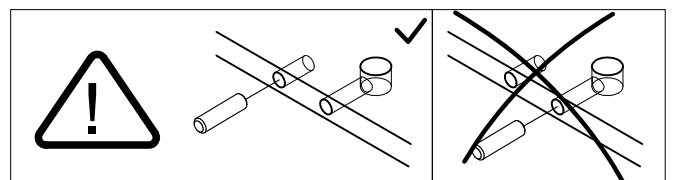
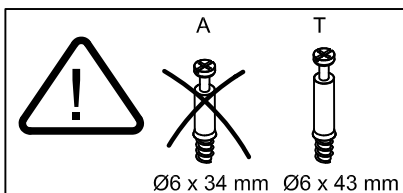
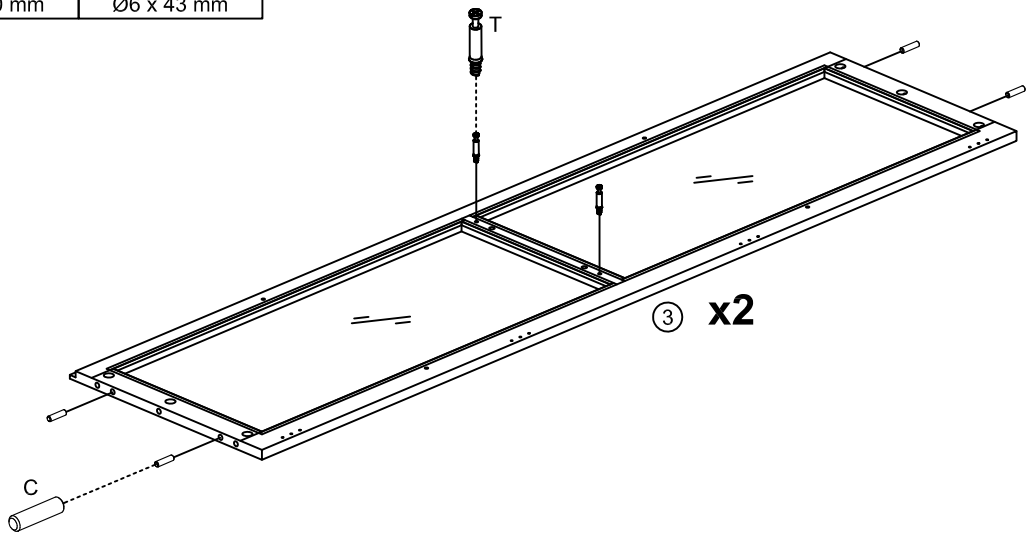
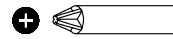
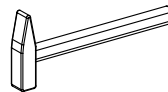
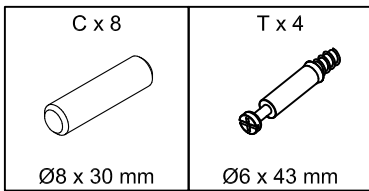

# 5

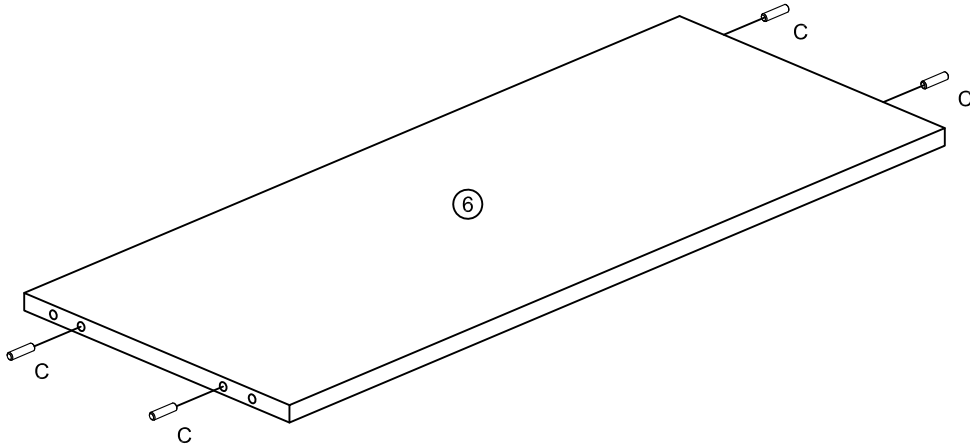
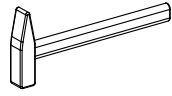
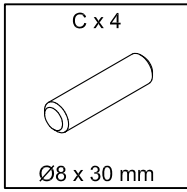

# 6

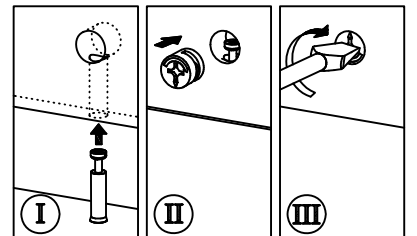
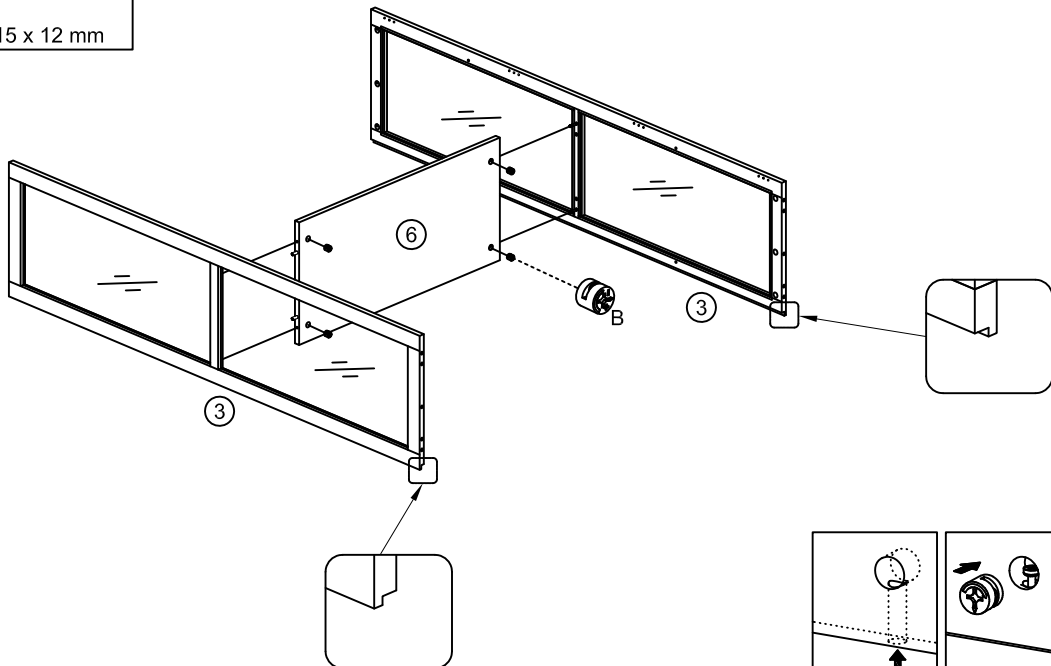
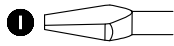
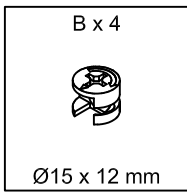

# 7

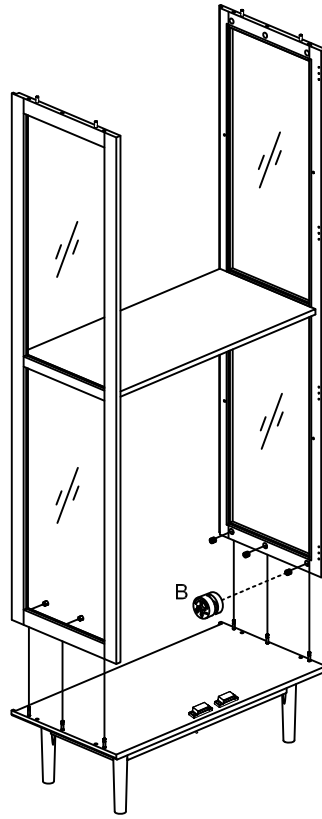
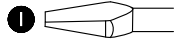
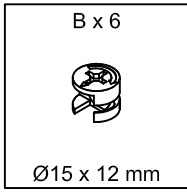

# 8

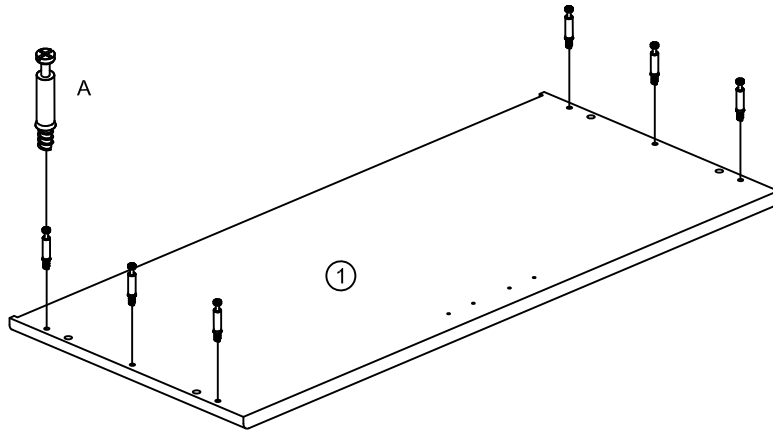
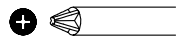
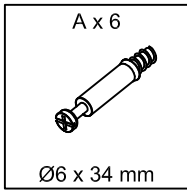

# 9

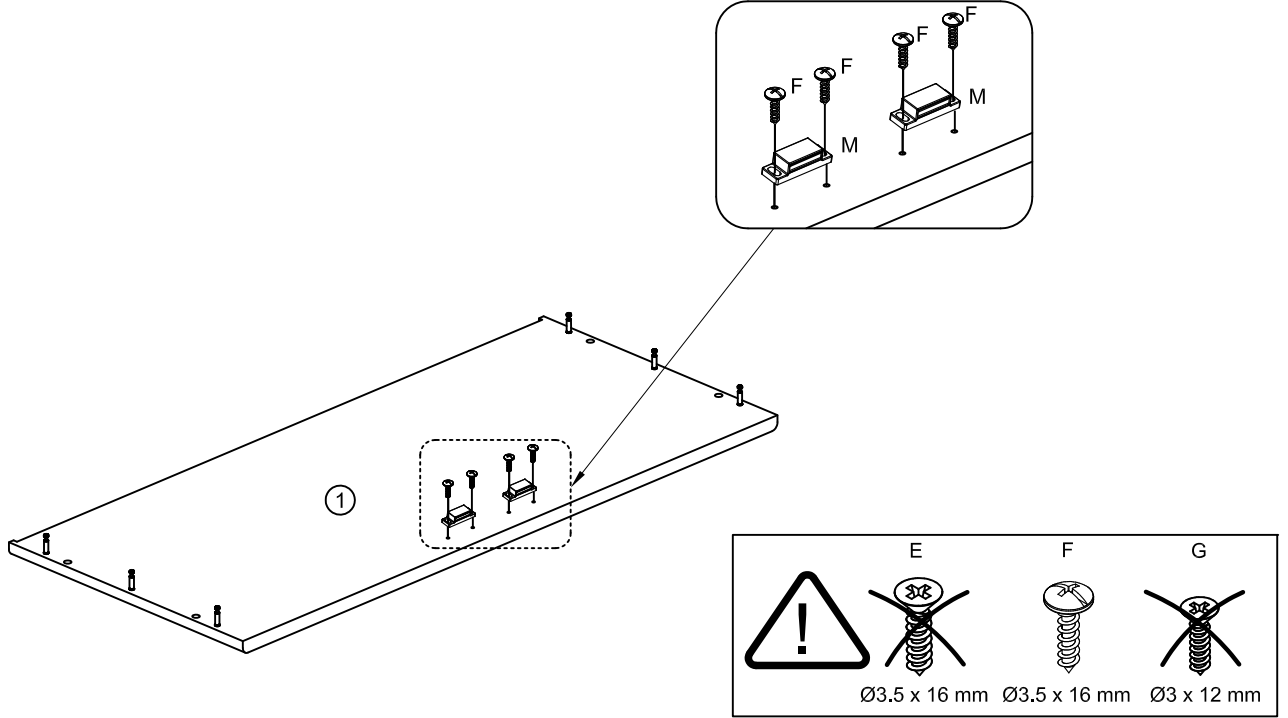
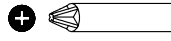
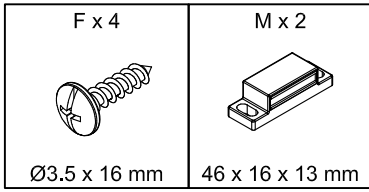

# 10

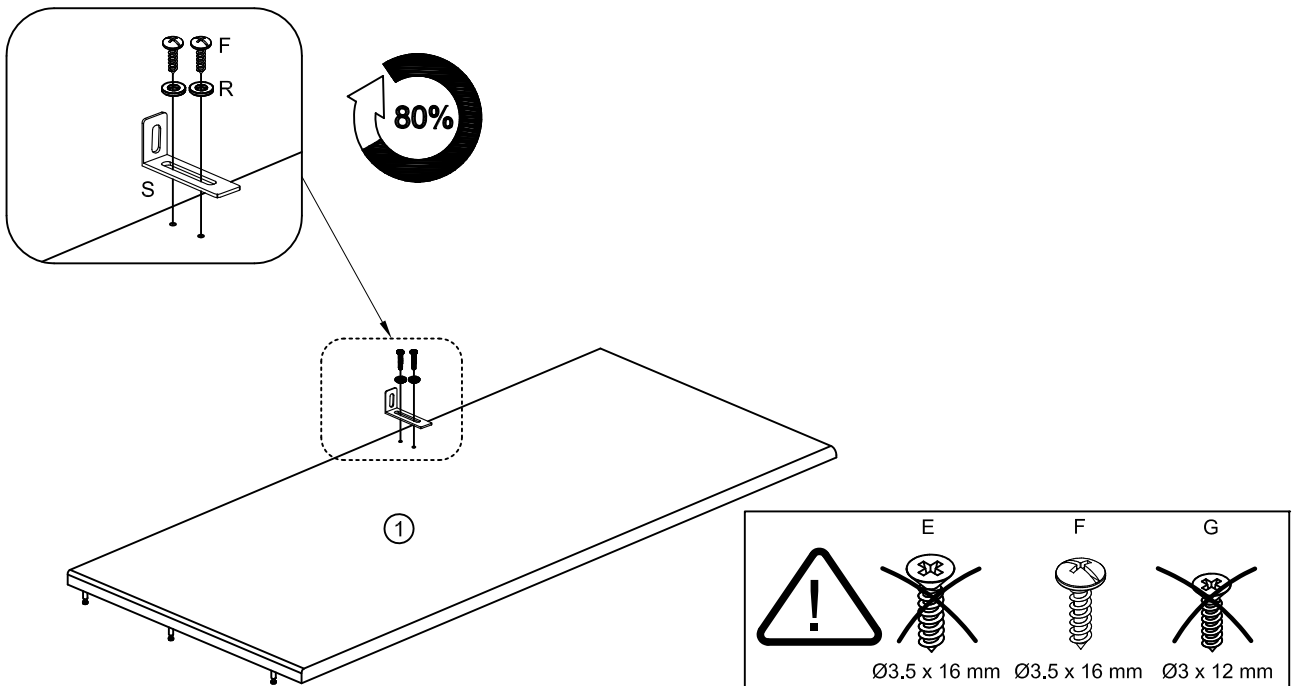
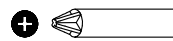
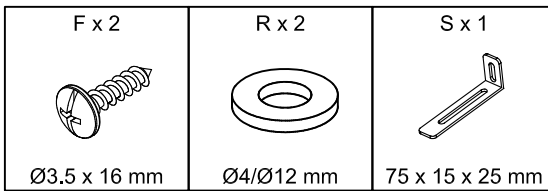



# 11

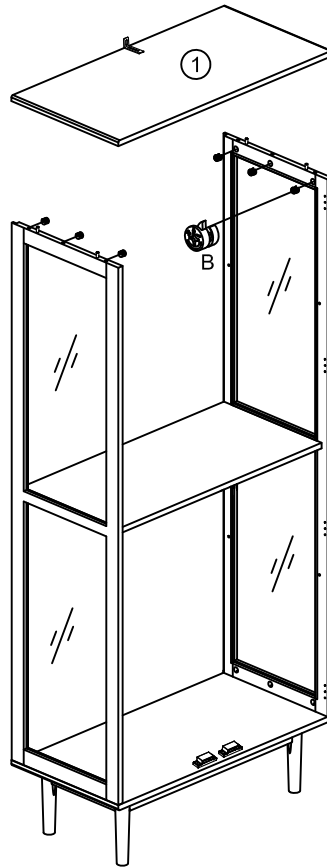
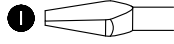
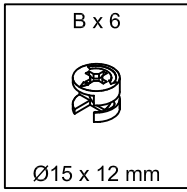

# 12

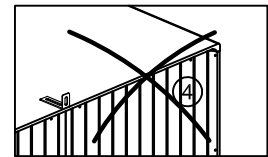
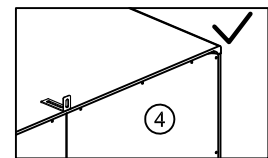
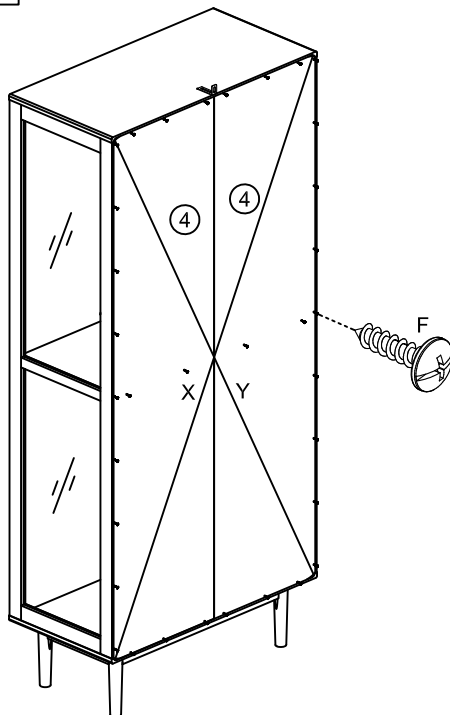
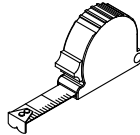
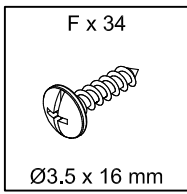

X=Y

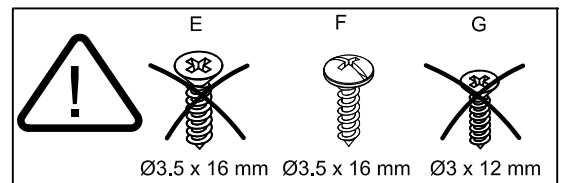
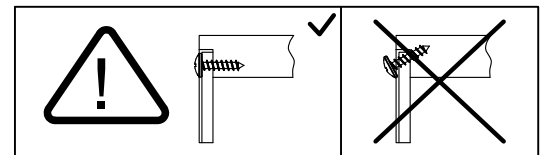

# 13

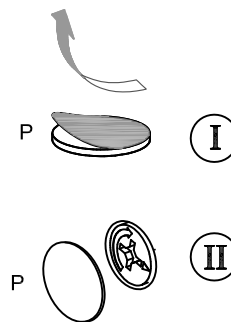
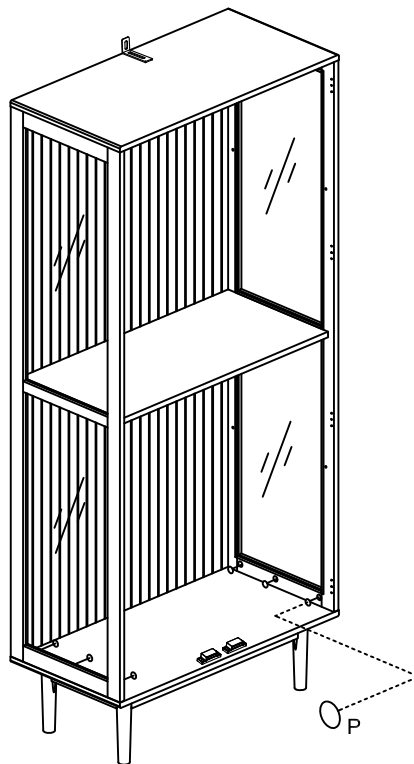
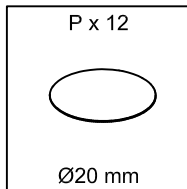

# 14

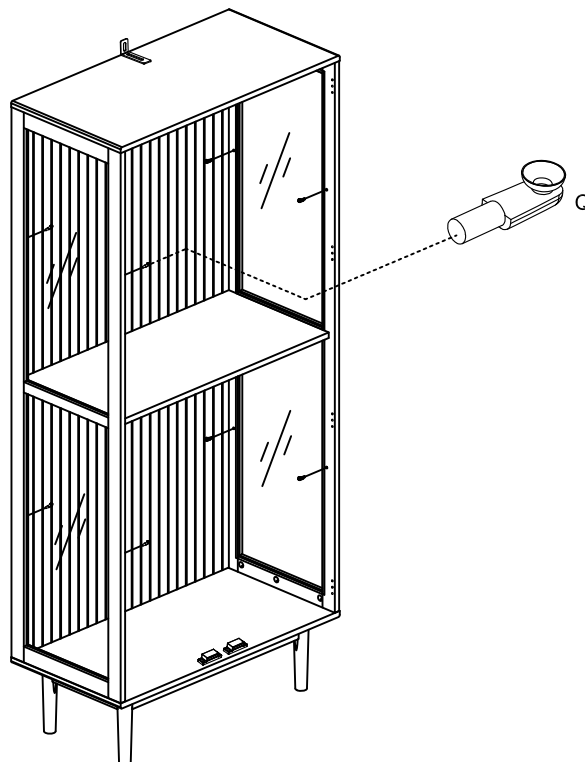
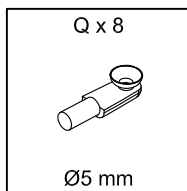

# 15

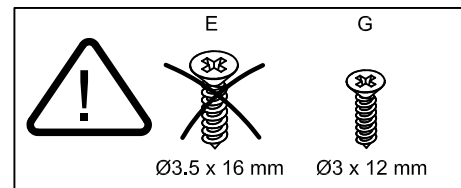
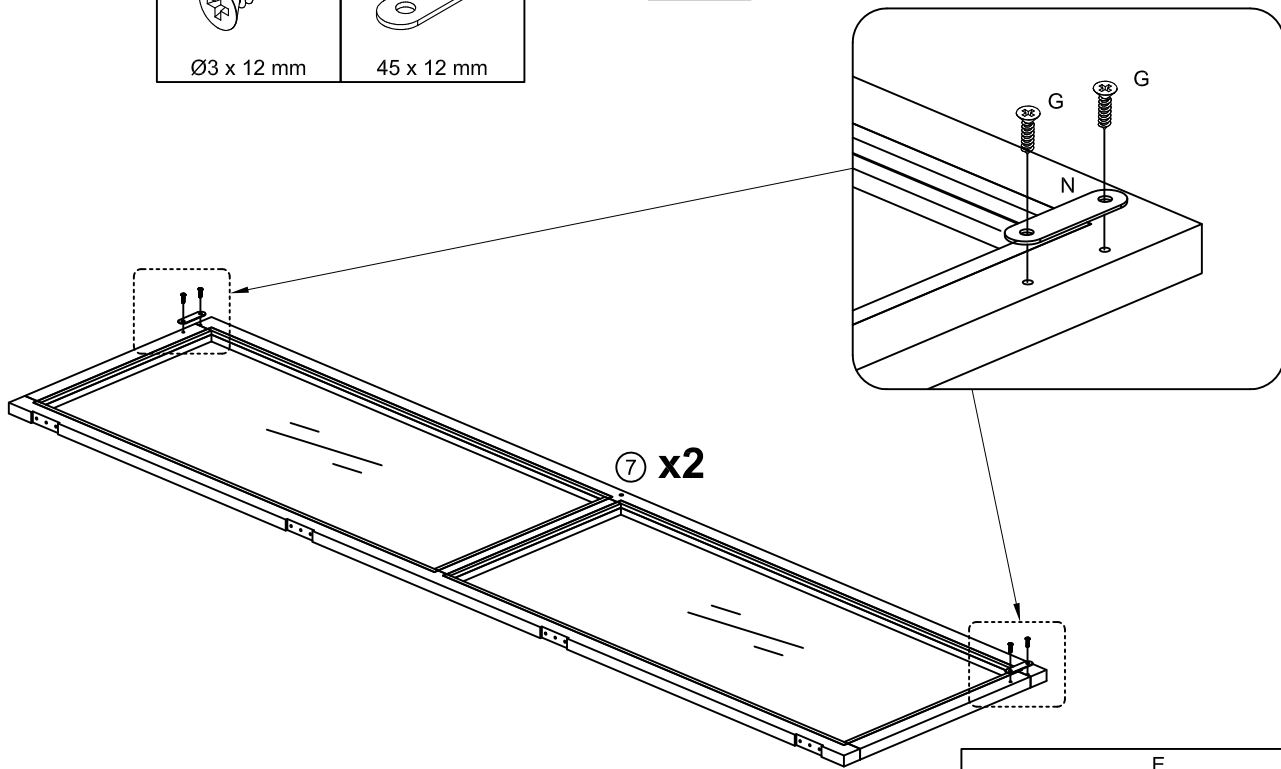
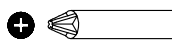
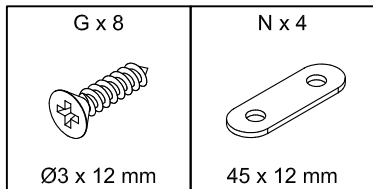

# 16

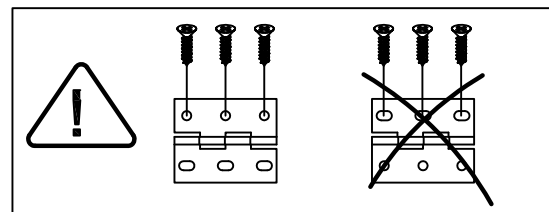
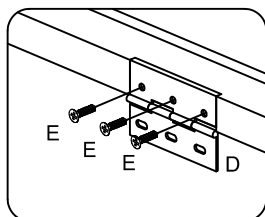
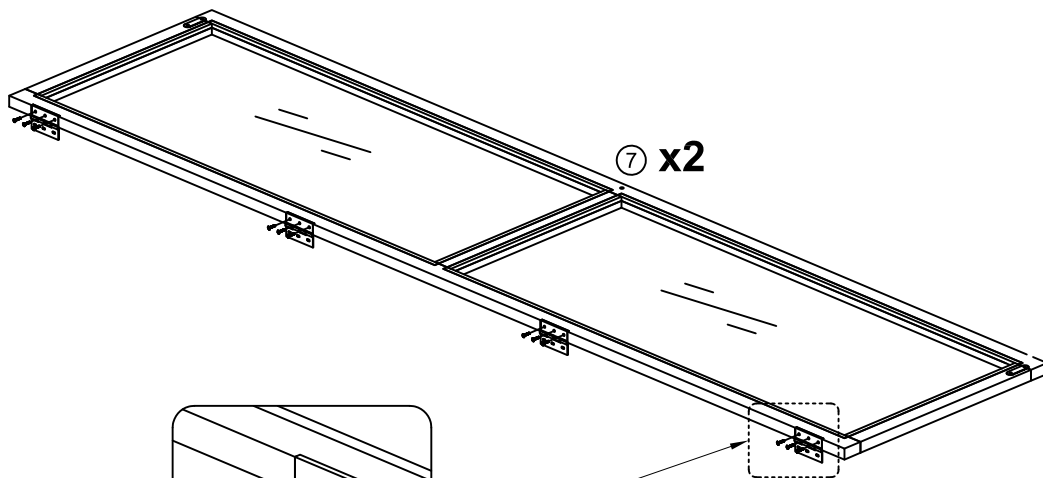
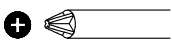
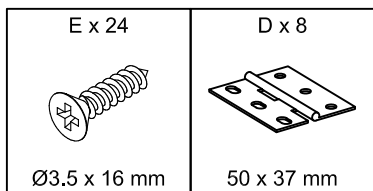

# 17

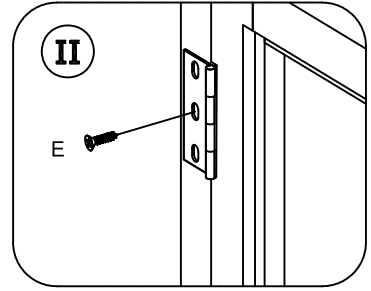
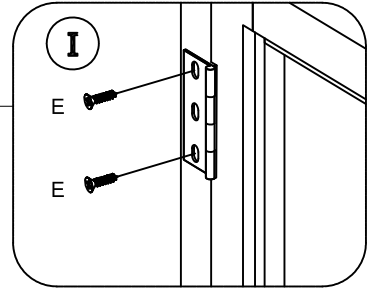
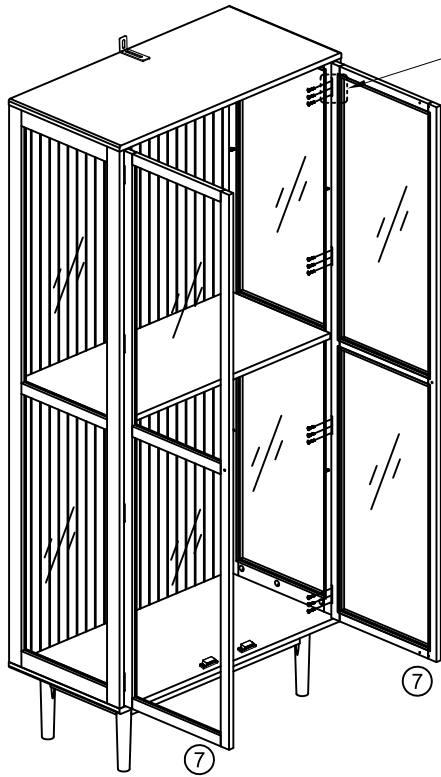
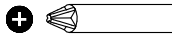
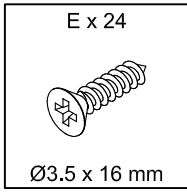

# 18

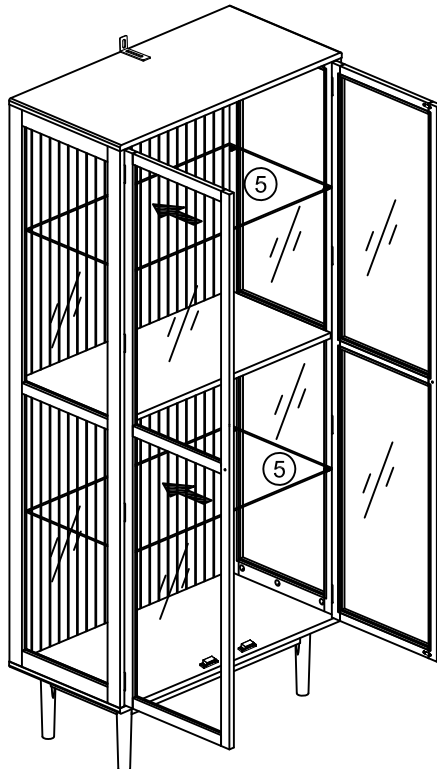

# 19

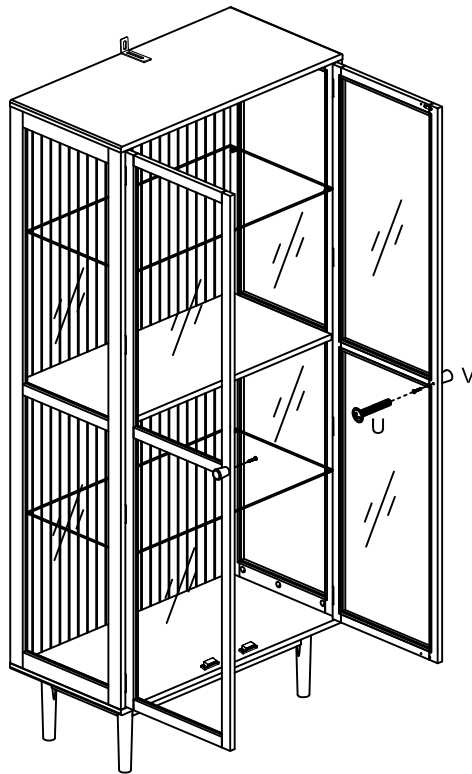
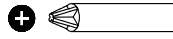
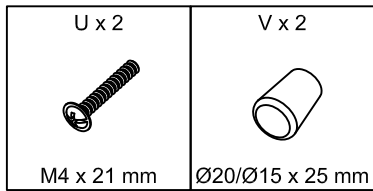

# 20

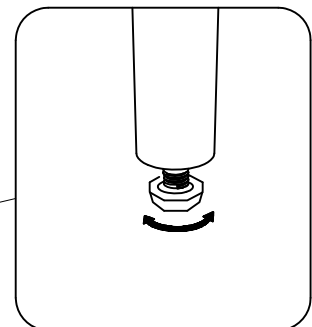
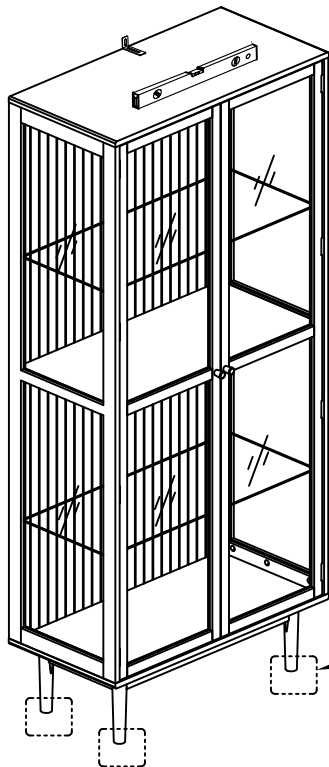
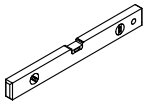

# 21

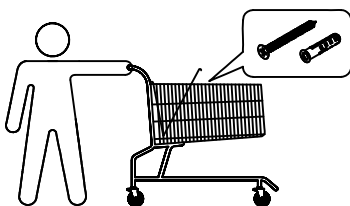
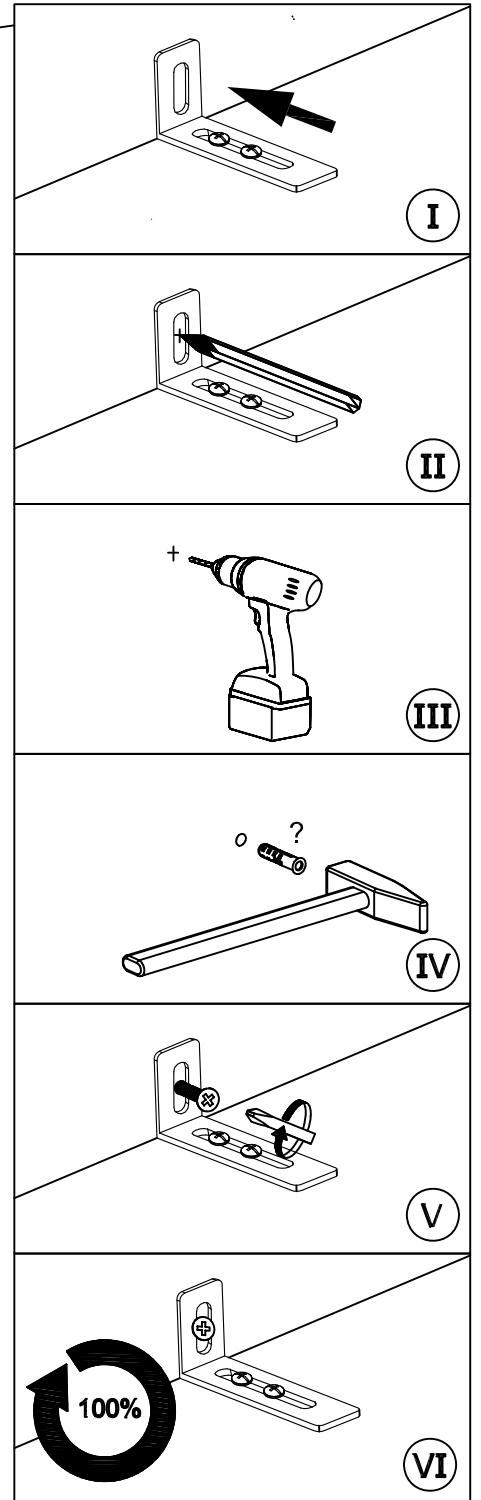
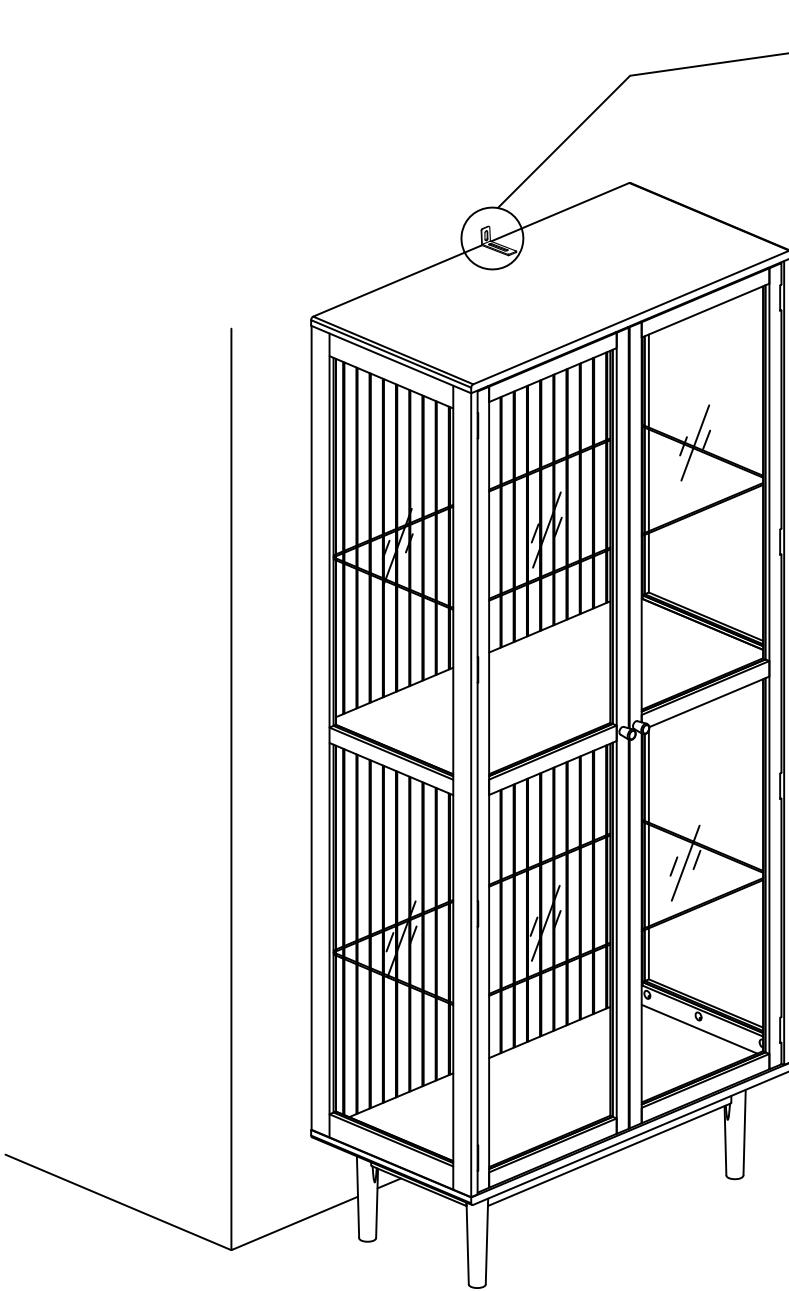
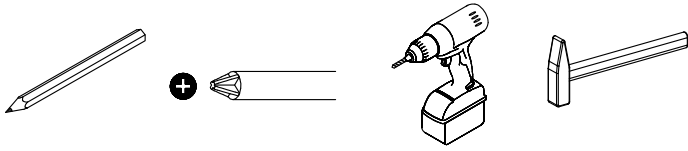

# 22

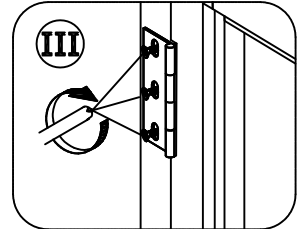
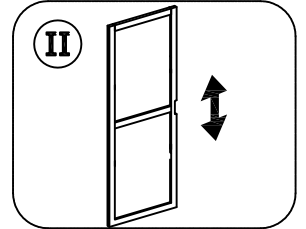
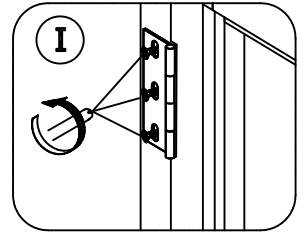
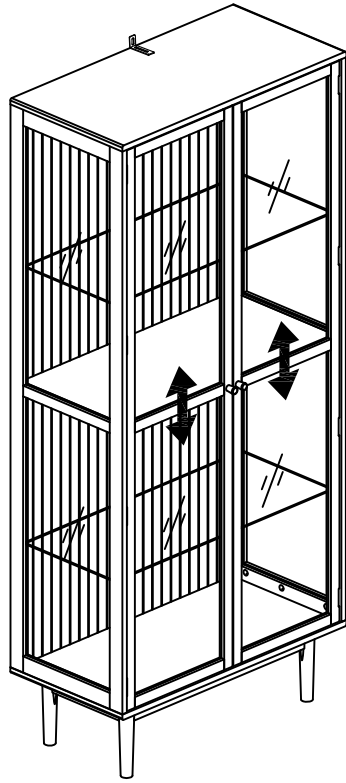
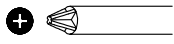

# 23

